



# SharkGuard Induction System (MKV)

Star Trading  
June 2025





# Assessing the efficacy of a novel shark bycatch mitigation device in a tuna longline fishery.



-91% (n=75)\*\*

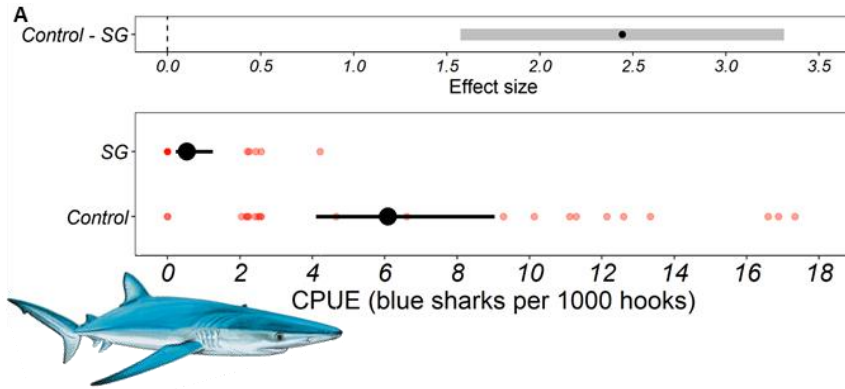

-40% (n=28)

-72% (n=270)\*\*

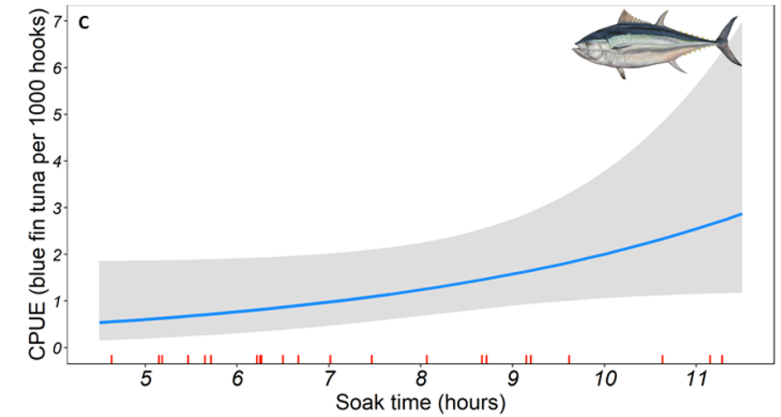
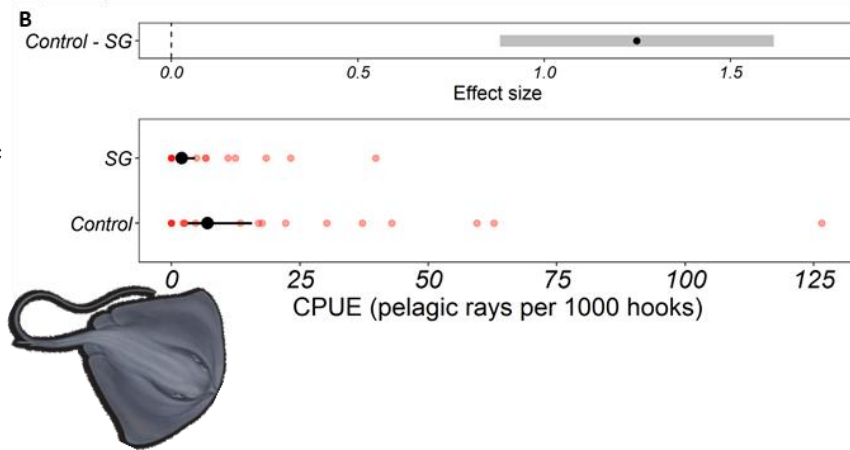

**Citation:** Philip D. Doherty, Robert Enever, Lucy C.M. Omeyer, Lydia Tivenan, Grant Course, Guy Pasco, David Thomas, Ben Sullivan, Ben Kibel, Pete Kibel, Brendan J. Godley, Efficacy of a novel shark bycatch mitigation device in a tuna longline fishery, Current Biology, Volume 32, Issue 22, 2022, Pages R1260-R1261, ISSN 0960-9822, <https://doi.org/10.1016/j.cub.2022.09.003>.

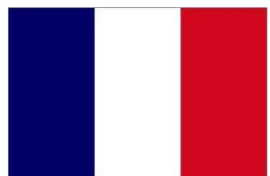

## Distance from hook comparison

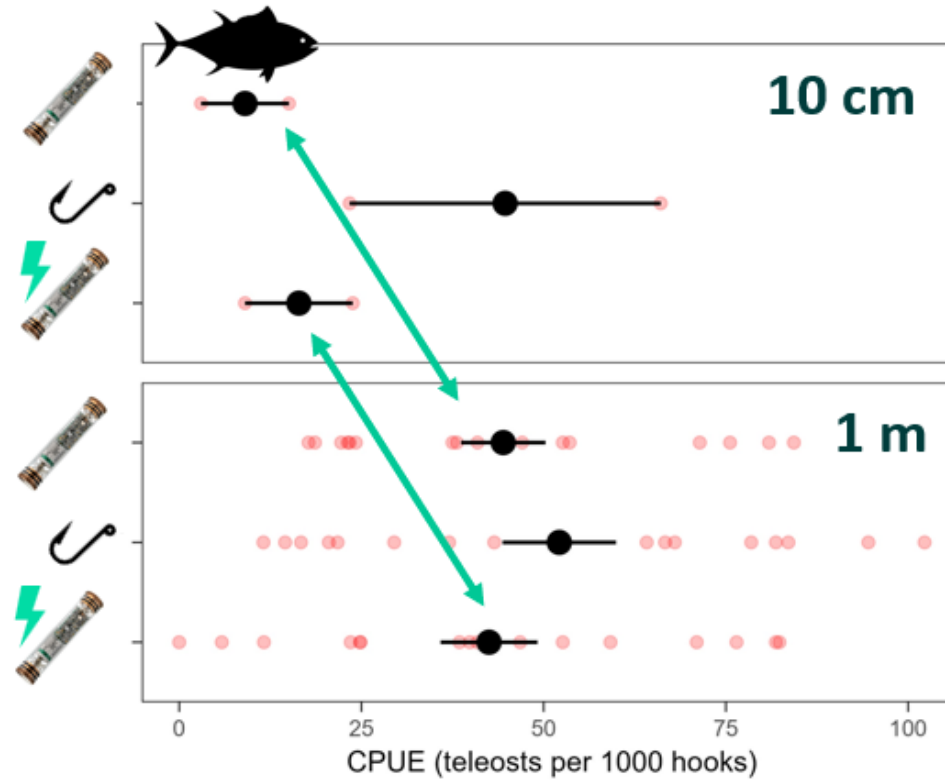

Improvement in teleost CPUE



# MINIATURISE & DISGUISE

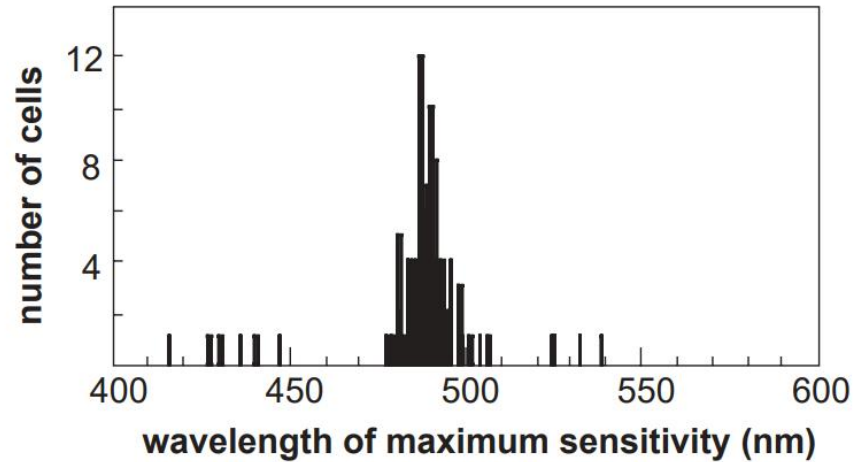
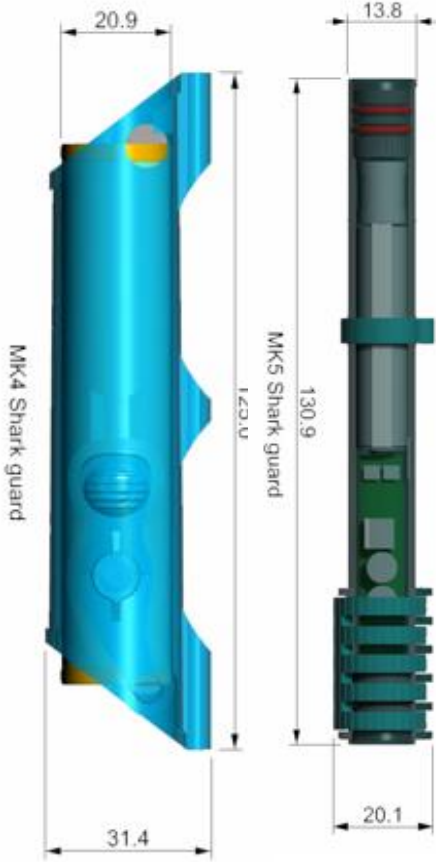
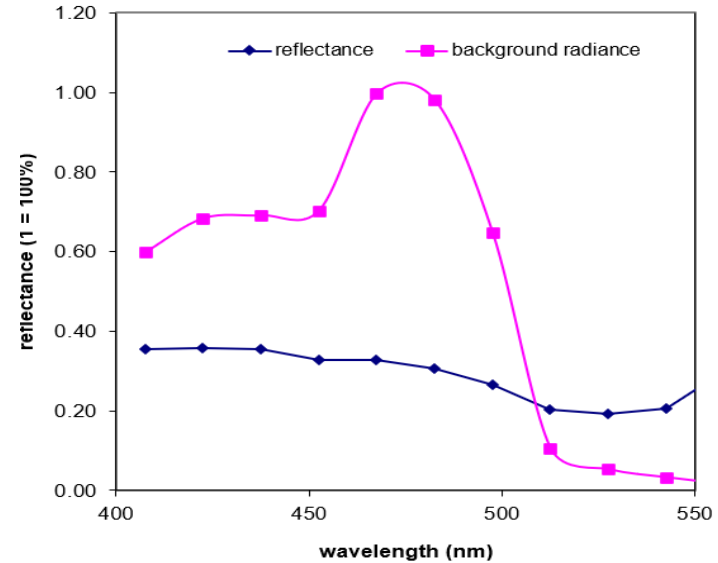
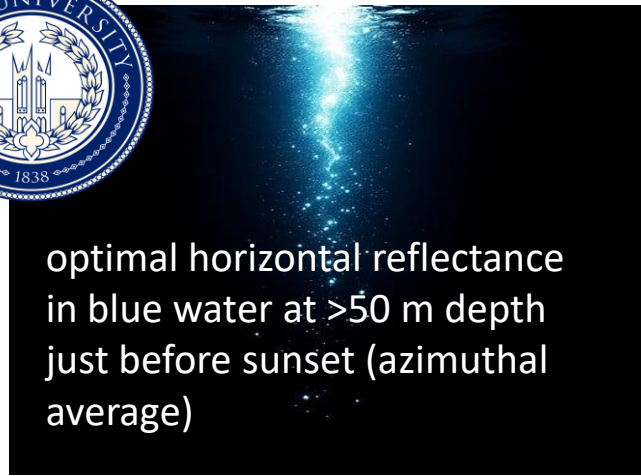
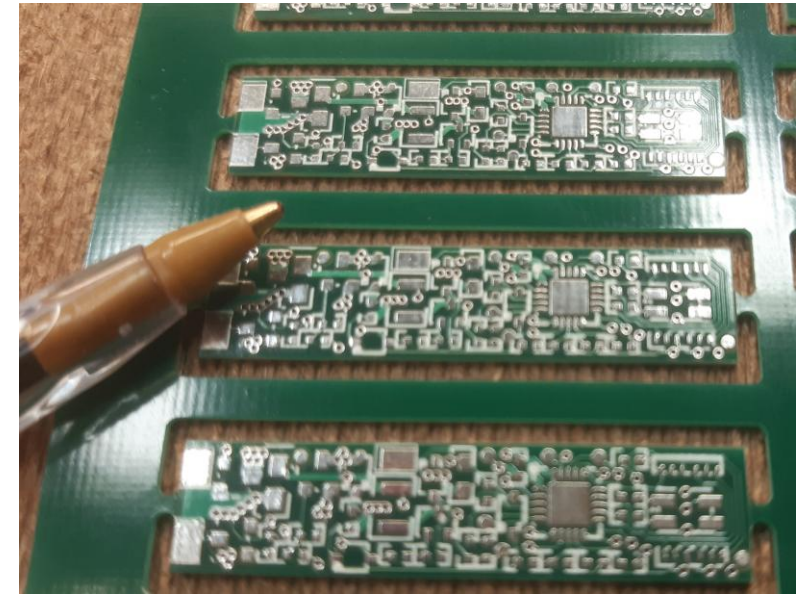
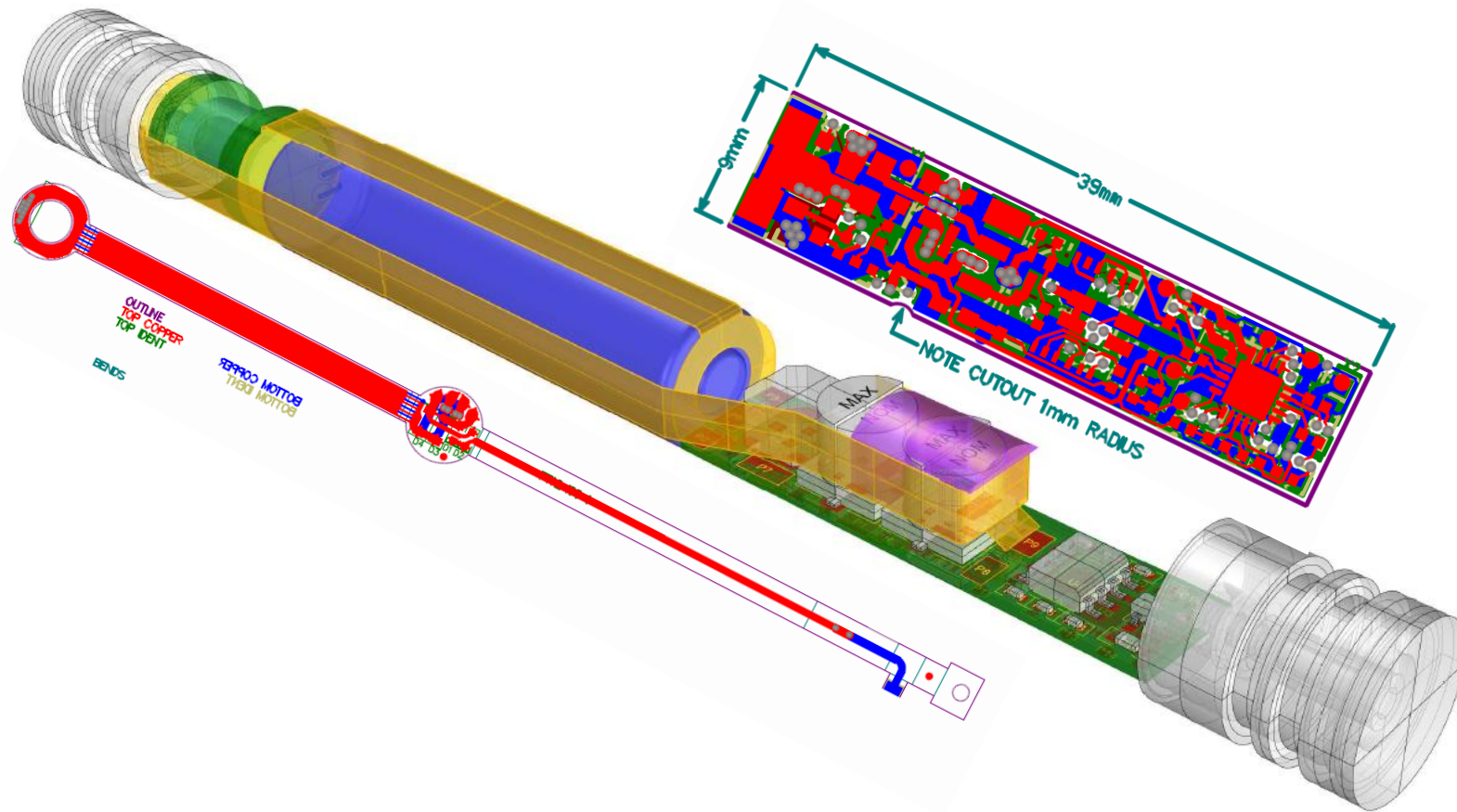

Figure 6. Distribution of visual pigments found in 115 photoreceptors in 5 species of tuna and billfish



average reflectance (weighted by radiance) is 32%. Munsell value N6.25 matte grey paint





“The step-up from MKIV to MKV is HUGE!! At least 5-fold the R&D”

A



B



# ELECTRONICS – INDUCTION CHARGING

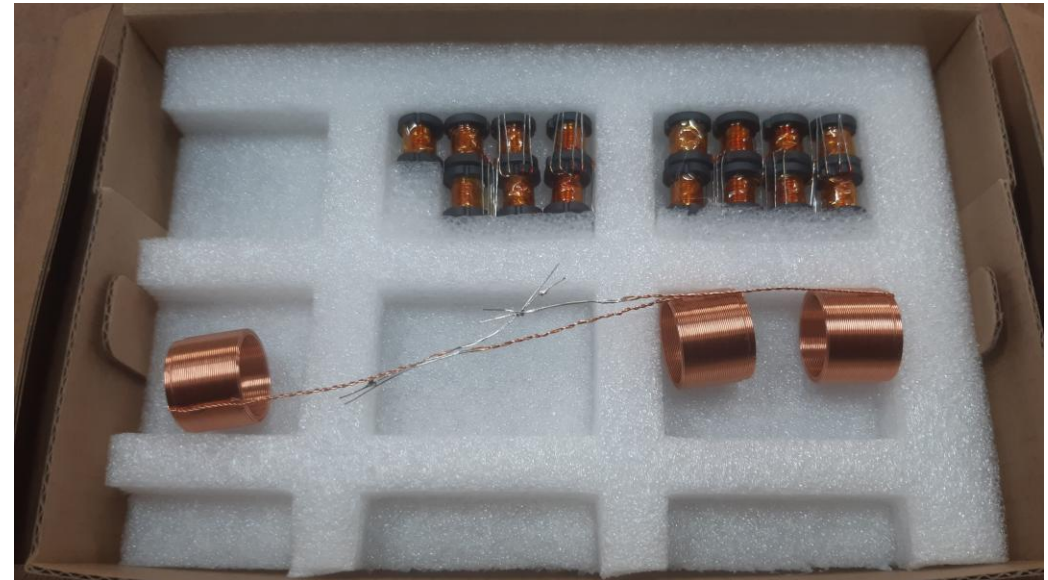
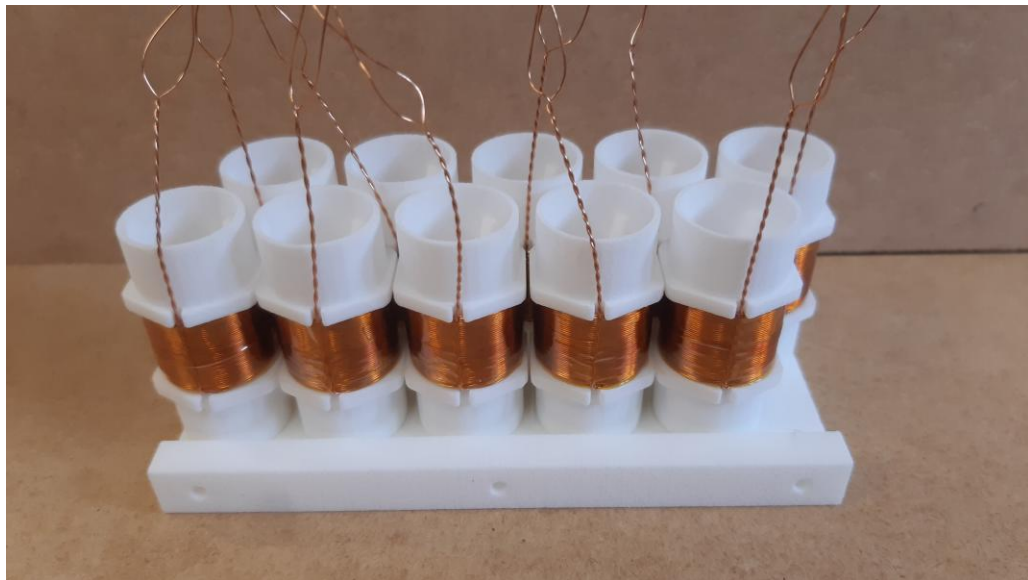
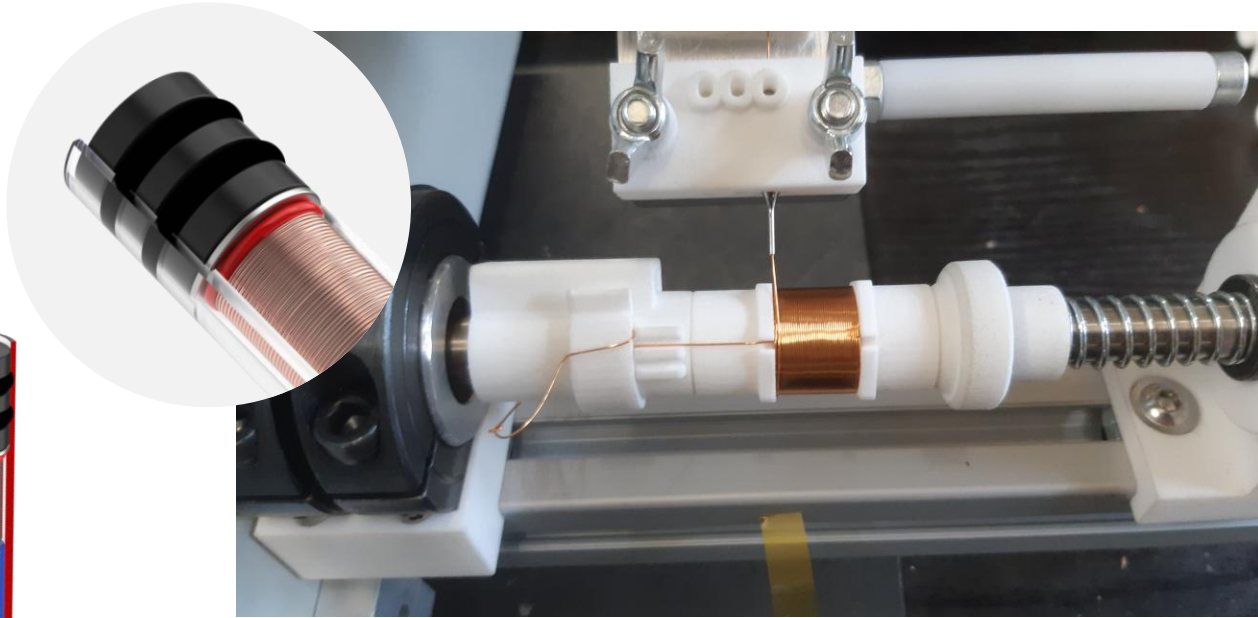

# ELECTRONICS – DOCKING STATION

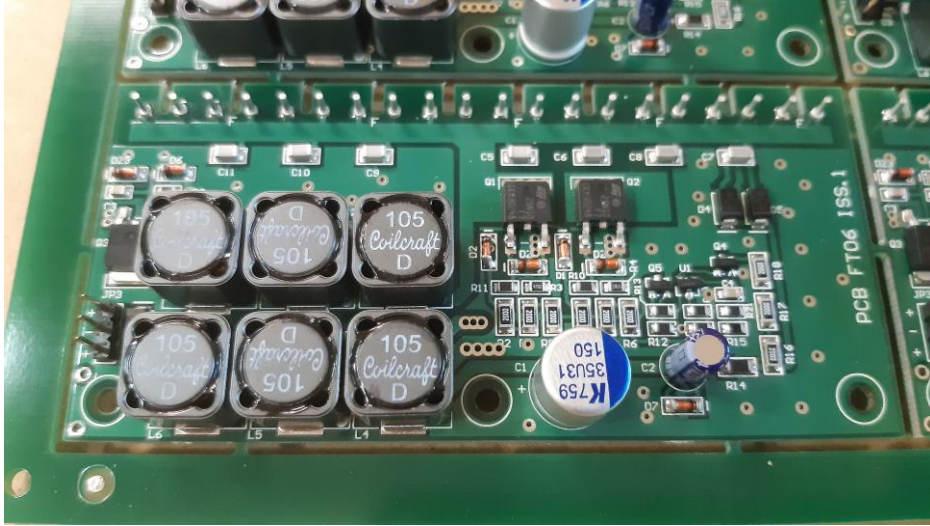

# ELECTRO MAGNETIC COMPATIBILITY (EMC) TESTING

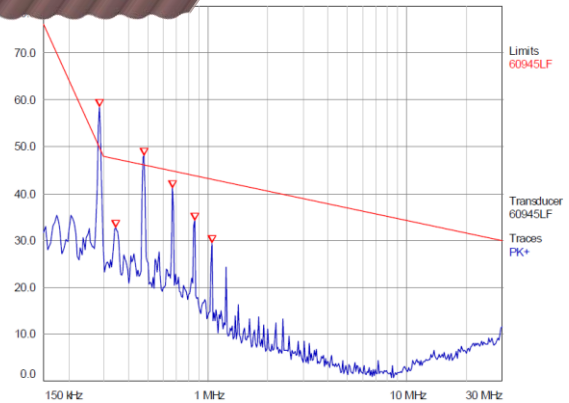
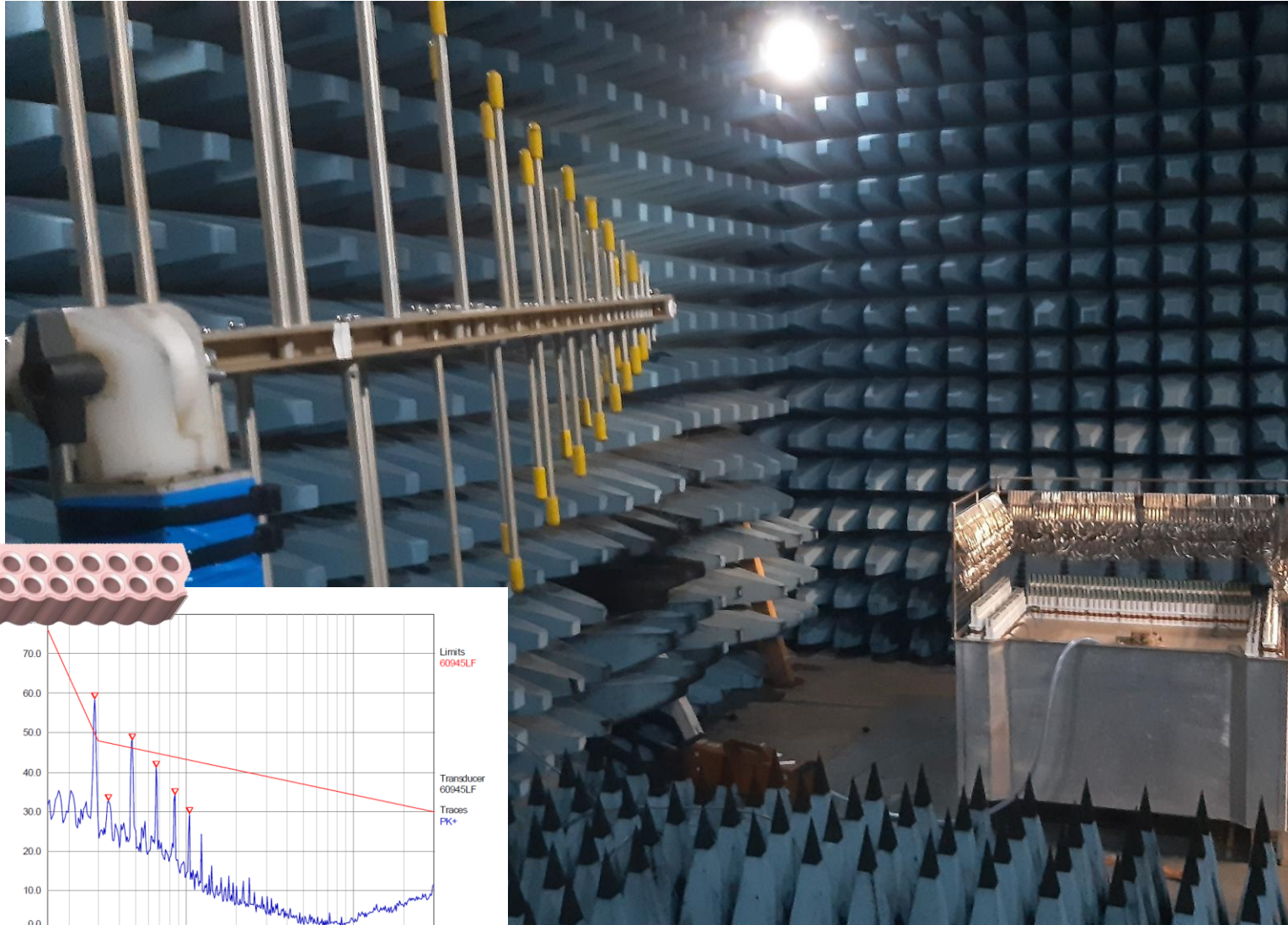

## Line attachment

Fisherman in practise were found to use line diameters ranging from 1.0 – 3.0 mm.

- Exploring line attachment mechanisms for sliding devices; both friction fit and clutch style mechanisms.
- Mechanisms that accommodate different line diameters; Discrete ranges (1.0 – 1.5 & 2.0 – 3.0) and universal systems (1.0 – 3.0 mm)

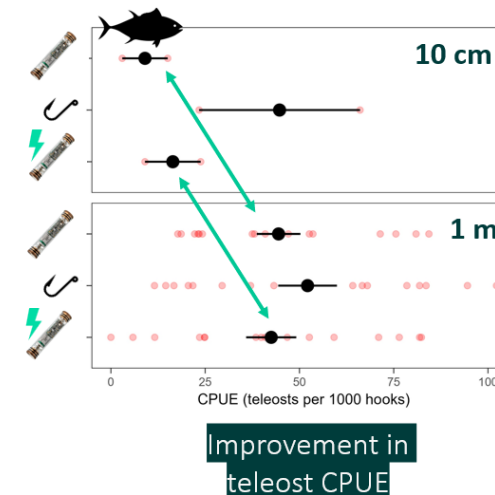

# MECHANICS – DOCKING STATION – “dock & release”

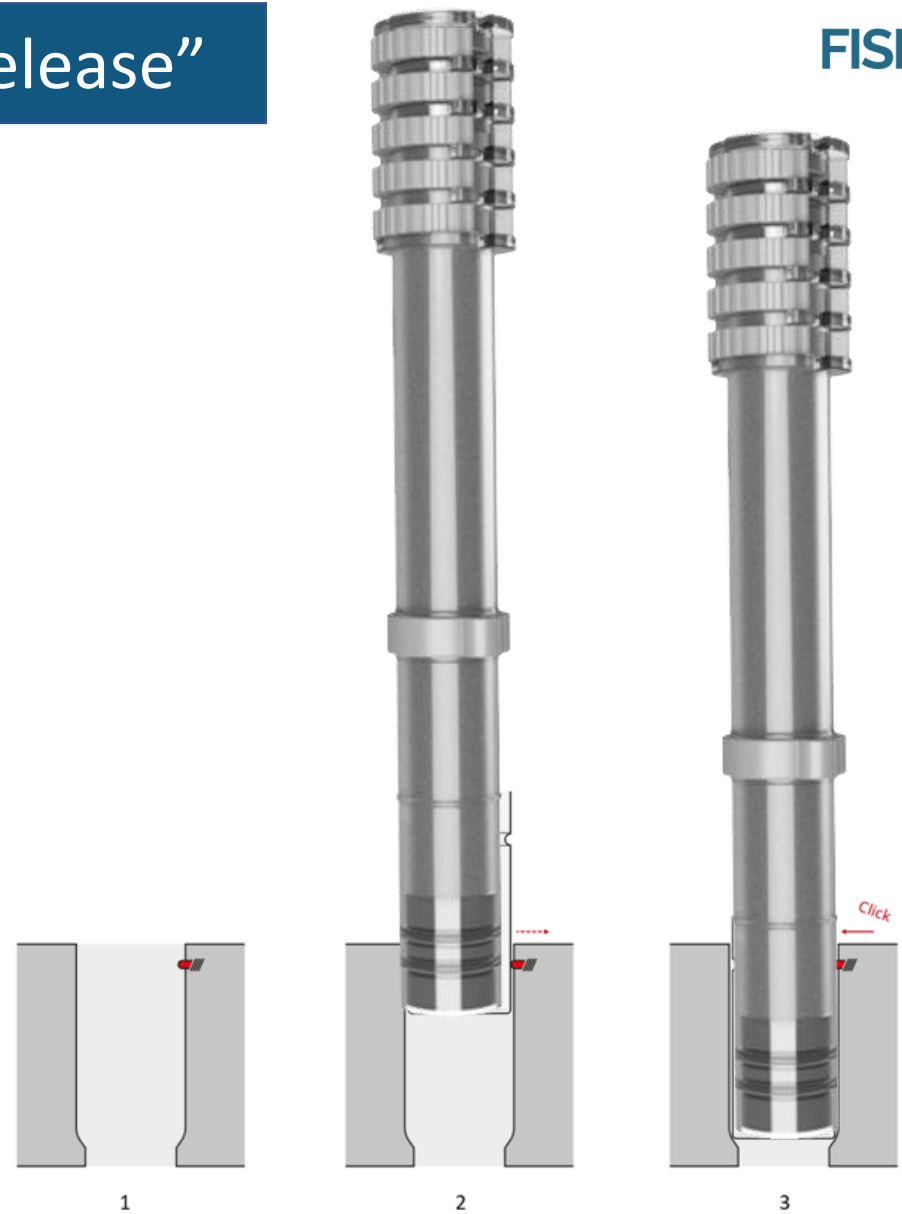

Each bay will include a retention feature to secure the SharkGuard during charging. It's retention force will be less than the grip force of the device on the line, so that on removing a clip and hook from the rail, the device will lift out of the bay rather than requiring the user to manually remove it. The design of the mechanism will also respect the charging coil and thus avoid metal components.

# Operational sea trials





# NEW APPLICATIONS – FAD GUARD



**TRI MARINE**  
TUNA DONE RIGHT SINCE 1972

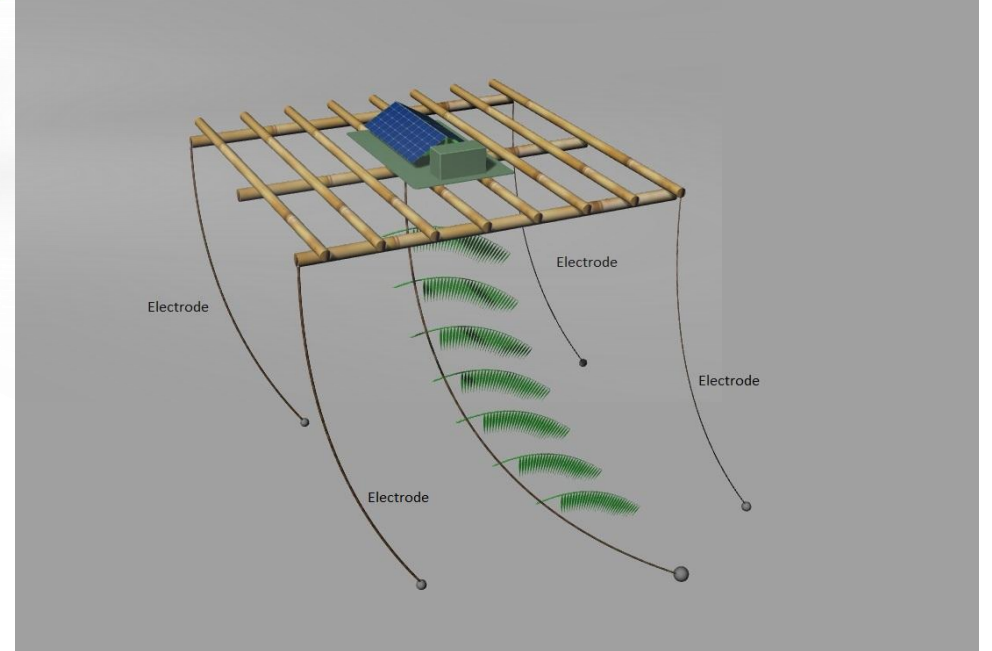

# Bottom-up drivers



## For the skipper

- Reduced depredation  
Of baited hooks  
Of target catch
- Increased hook availability
- Opens ground opportunity
- Less gear entanglement (time/cost)
- Built in light-sticks (reduced disposable costs)

# Middle down drivers

## MSC CRITERIA

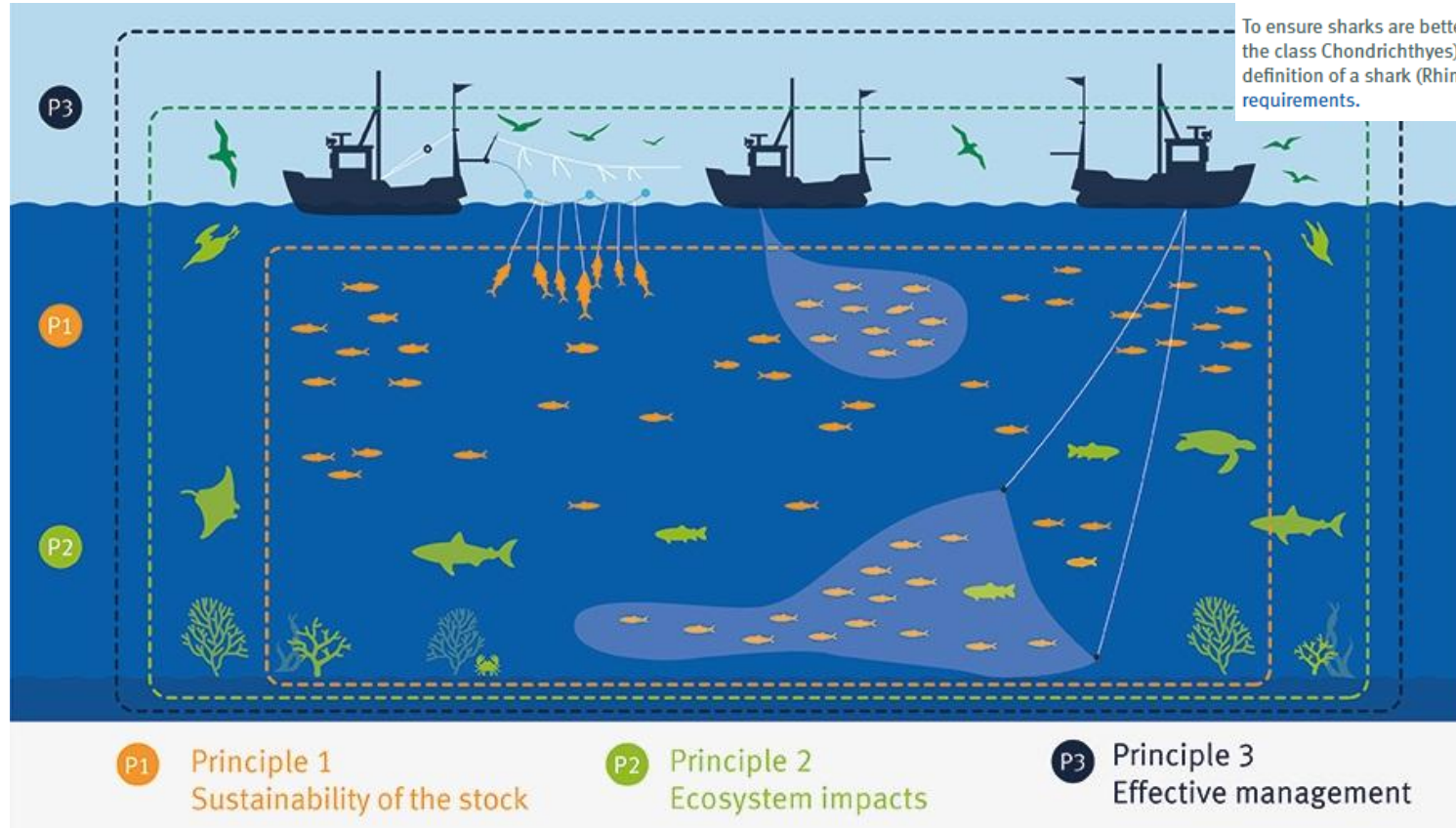

### Better protections for sharks

We have also designed our new ETP classification system with greater precaution for sharks. Sharks which are protected under national ETP legislation or those identified by IUCN as endangered, critically endangered, or listed as CITES or CMS Appendix 1 species all automatically qualify as ETP species (so cannot be eligible for MSC certification).

In certain circumstances, sharks listed on CITES Appendix 2 and CMS Appendix 2 may be assessed under Principle 1 or subject to our requirements for in-scope species rather than ETP/Out-of-Scope. However, this can only occur only if the specific stock meets the scientific criteria set out in Step 2 of the process detailed above, demonstrating that the specific stock has a healthy population size and is well-managed.

To ensure sharks are better protected, we have also expanded the definition of 'shark' to include all shark species (from the class Chondrichthyes) for the purposes of classifying a species as endangered, threatened, or protected. The definition of a shark (Rhinopristiformes and Selachimorpha) remains unchanged in relation to our shark finning requirements.



**briefing CITES Appendix II Requiem shark listing**

# Middle-down drivers

## CORPORATE ENVIRONMENTAL & SOCIAL GOVERNANCE



*As of March 2021, European corporations are incentivised to report strong Environmental, Social and Corporate Governance (ESG) credentials in their annual accounts to prevent divestment from fund managers under the EU Sustainable Finance Disclosure Regulations (SFDR; EU, 2019).*



*For retail corporates wanting high ESG scores it is likely that seafood procurement will rapidly shift towards sustainable fishing methods.....*



John West tuna won't be available at Tesco stores (Image: Mirrorpix)



### Tesco dumps John West tuna from its shelves for failing to meet strict environmental standards

The company is still trawling for tuna using methods that attract, net and kill other species such as dolphins, sharks and turtles

# Top-down drivers



- International Plan of Action – sharks, seabirds in longline fisheries, fishing capacity
- National Plan of Action for the conservation and management of sharks (n=10)
- a global platform for the conservation and sustainable use of migratory animals and their habitats.

- Strategic Goal B: Reduce the direct pressures on biodiversity and promote sustainable use

- International trade – all requiem sharks – COP19

- The international and national frameworks for conservation and management of sharks: Recommendations for Ecuador

## RMFOs

CMM – Conservation and Management Measure – sea turtles, sharks, seabirds

Sharks: Minimizing bycatch and practicing safe release